

# INSPIRATIONS

EMBROIDERY DESIGNS · INSTRUCTIONS · PATTERNS



## CHRISTMAS SPIRIT

BY BETSY MORGAN

For colour photos and full details, see pages 32–41.

### PRINTING GUIDELINES / PAGE SCALING

Print all pages at 100% (actual size). Choose “none”, not “shrink to fit” or “reduce to fit”, in the print dialogue box. Refer to the measurements along each edge to ensure you have printed correctly.

[www.inspirationsstudios.com](http://www.inspirationsstudios.com)

Inspirations issue 104 · Copyright reserved ©2019 Inspirations Studios

This design is for private use only.

Permission to reproduce or copy any of the contents for any other purposes must be obtained from the publisher in writing. Inspirations Publications has taken reasonable steps to secure the copyright for the items reproduced in this publication. Articles are published in reliance upon the representations and warranties of the contributors and without our knowledge of any infringement of any third party. Information and instructions given are presented in good faith. As we have no control over physical conditions surrounding application of information contained in this project, the contributors and publisher disclaim any liability for untoward results.

# Cutting Out

## Cutting layout

RED SILK DUPION

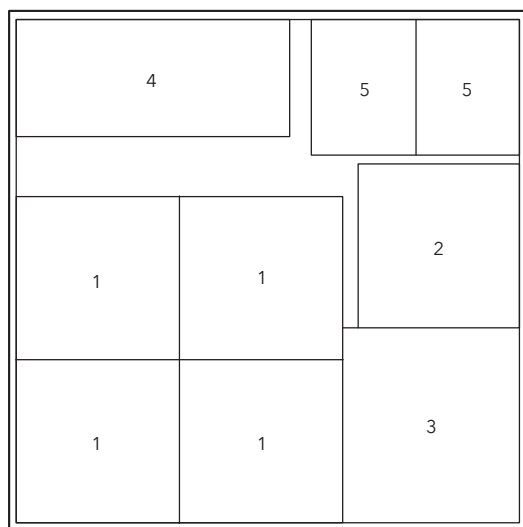

1. etui sides (4)
2. etui base
3. etui lid
4. scissor sheath lining
5. needlebook (2)

## Construction

All seam allowances are 13mm (1/2") unless otherwise specified.



right side of fabric



interfacing



interlining

### 1. Preparing the embroidered linen

Remove any remaining tacking. Place the embroidered linen face down onto a soft, padded surface and press with a warm, dry iron, squaring the corners and straightening the edges.

### 2. Making templates

Make a photocopy of each piece of stitching and two copies of the needlebook and box lid. Label and cut out one photocopy panel of each piece just inside the back stitch outline. These will be used to cut the lightweight interfacing and interlining for the linen to the exact size for each piece. Cut out the second photocopy of the needlebook and etui lid just outside the back stitch border. These will be used to cut the interlining for the silk for these pieces.

### 3. Preparing the lightweight interfacing

Using the templates, cut and label pieces of lightweight interfacing to fit inside the back stitch border of each panel.

### 4. Applying the lightweight interfacing and cutting out the linen

Position the pieces of lightweight interfacing, adhesive side down, over the wrong side of the stitched panels, checking to ensure that the interfacing sits just inside the back stitch outline. Fuse in place. Cut out each piece leaving a 13mm (1/2") seam allowance from the back stitch outline.

## 5. Twisted cords

Make the following twisted cords. At the knotted end, bind the cord securely beneath the knot with matching thread. Trim away the end of the cord flush with the binding (diag 1).



diag 1

**Etui:** one 50cm (20") cord using six strands of **A** and one 23cm (9") cord using 4 strands of **A**.

**Scissor fob:** one 33cm (13") cord using six strands of **A** and one 23cm (9") cord using 4 strands of **A**.

## 6. Tassels

**Etui:** Fold the 50cm (20") cord in half and make a tassel over the centre loop. To make the tassel, wrap the piece of firm card with **A** until the skirt is the desired fullness. Cut the thread bundle at the base (diag 2).

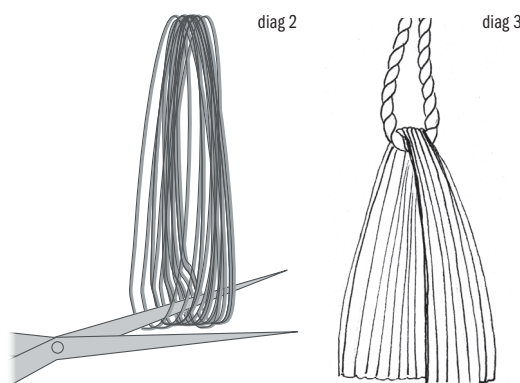

diag 2

diag 3

Take one end of the bundle over the centre of the twisted cord (diag 3).

Securing the ends in the bundle and beginning 7mm (5/16") down from the tassel top, wrap one 23cm (9") twisted cord around the thread bundle to form the tassel neck. Trim the base of the tassel skirt so that it is even.

**Scissor fob:** Bring the bound and looped ends of the 33cm (13") cord together and stitch securely (diag 4).

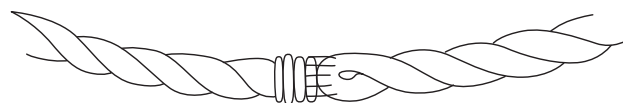

diag 4

Make a tassel over the joined ends in a similar manner to the etui tassel, using the remaining 23cm (9") cord.

## 7. Preparing the etui

Using the six linen pieces as templates, cut six pieces of silk the same size. Using the photocopy templates, cut two pieces of interlining for each side and the base panel and one piece for the lid. Using the second photocopy, cut one piece of interlining for the lid lining. Label this piece clearly.

Place the interlining for the base and lid on a flat surface. Using the ruler and black pen, find the centre of each square by ruling lines diagonally from corner to corner. Cut out a small square with the craft knife where the lines intersect (diag 5).

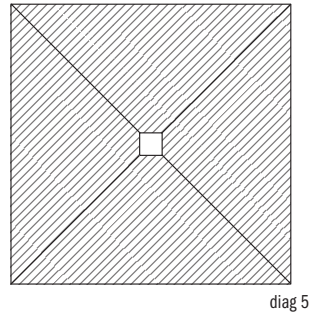

diag 5

Cut out the star from the red felt and the circle from the gold felt. Mark the centre of each one using the templates. Using a hole punch or small, sharp scissors, make a neat circular hole at the centre point.

Using **C**, work blanket stitch around the centre hole on each piece. On the circle, work a ring of French knots using two strands of **B** and blanket stitch around the outer edge using one strand of **C**. Using the craft glue and aligning the centre holes, glue the circle to the star and allow to dry (diag 6).

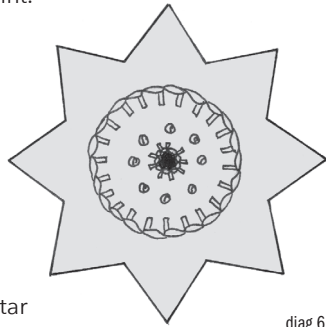

diag 6

Work the flowers on the star, placing one into each point using **B** for the straight stitch foliage and two strands of **F** for the French knot flowers. Centre the star on the lid panel, aligning a point with each corner, pin and tack in place with the white sewing thread. Remove the pins. Using **C**, blanket stitch the star to the linen around the outer edge. Remove the tacking.

Prepare each linen panel by positioning the interlining on the back, mitreing the corners and folding in the seam allowance. Stitch the mitres with the white sewing thread and lace the linen on the back of each panel (diag 7).

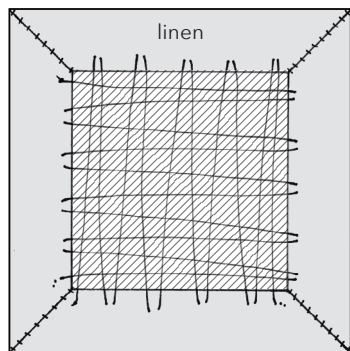

diag 7

Prepare the lining panels in a similar manner, folding in the seam allowances and mitreing the corners on the upper and side edges only, leaving the seam allowance on the lower edge loose. Use the red sewing thread and press the seam allowances in place.

### 8. Assembling the etui

Working along the top edge only and using the red sewing thread, stitch the silk lining panels to the linen side panels using joining stitch and the crewel needle, centring the lining on the back of the linen (diag 8).

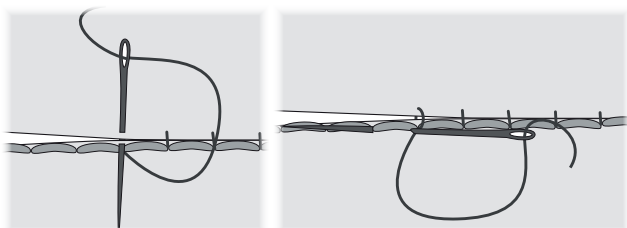

diag 8

Stitch the lid lining to the lid around each side in the same manner using the red sewing thread. Open up a hole at the centre of the lid lining with the dressmaker's awl, pushing it through the hole at the centre of the lid. Repeat on the base lining.

Using **A** and a tapestry needle, stitch the four linen panels together along the side seams using joining stitch in the following order, whitework panel, tree panel, Bargello panel and partridge panel (diag 9).

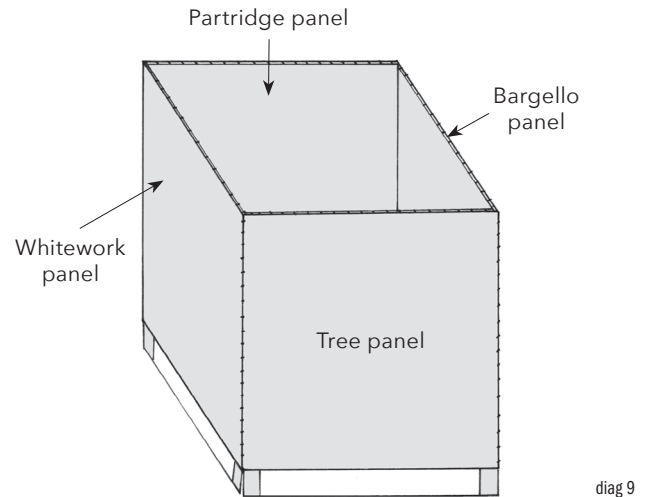

diag 9

Take each end of the etui tassel cord through one hole of the mother of pearl button then take both ends down through the hole in the centre of the lid. Take the ends down through the hole in the base lining and through the square formed by the joined sides. At the centre of the interlining on the back of the linen base, stitch approximately 13mm (1/2") of the ends securely to the interlining only (diag 10).

Using joining stitch and **A**, stitch the linen base to the lower edge of the box sides, folding in the loose seam allowances. Push the base lining down the cord until it sits snugly inside the base of the box.

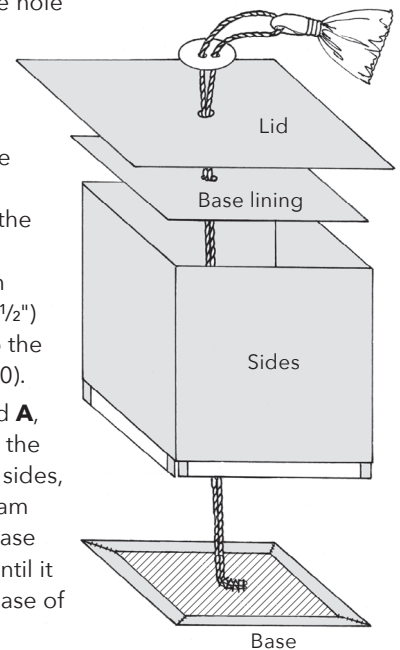

diag 10

### 9. Scissor sheath

Use the linen piece as a template to cut the lining in the same manner as the etui. Using the photocopy templates, cut two pieces of interlining to fit inside the back stitch border. Position the interlining inside the back stitch border on each side of the sheath, mitre and stitch the corners, fold in the seam allowance and lace the edges using the white sewing thread (diag 11).

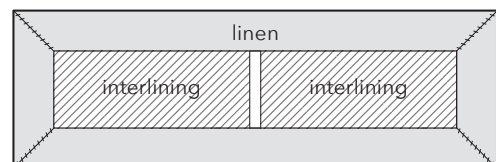

diag 11

Cut the piece of heavyweight fusible interfacing so that it measures 4.3cm x 13.6cm (1<sup>11</sup>/<sub>16</sub>" x 5<sup>3</sup>/<sub>8</sub>") then cut in half so that you have two pieces that measure 4.3cm x 6.8cm (1<sup>11</sup>/<sub>16</sub>" x 2<sup>3</sup>/<sub>4</sub>"). Centre the pieces on the silk lining, leaving a 2mm (1/16") gap between the short ends and fuse in place (diag 12).

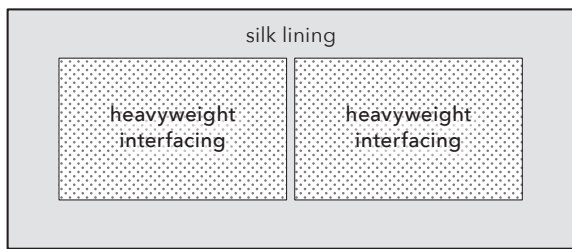

diag 12

Mitre and stitch the corners, fold in the seam allowance and press in the same manner as the etui. With wrong sides facing, centre the lining over the prepared linen, taking care to ensure that the gaps in the interlining and heavyweight interfacing are aligned. Stitch the lining to the seam allowance of the linen only. Fold the scissor sheath in half and using joining stitch and **A**, stitch the sides together.

### 10. Needlebook

Use the linen pieces as templates to cut the lining in the same manner as the etui. Using the photocopy templates cut a piece of interlining to fit inside the back stitch borders. Position one piece of interlining, mitre and stitch the corners and fold in the seam allowance on each side. Lace the edges and press gently. Using the second templates, cut two pieces of interlining for the silk lining. Prepare the silk lining in the same manner. Cut two pieces of gold felt to measure 5.5cm x 4cm wide (2<sup>1</sup>/<sub>8</sub>" x 1<sup>1</sup>/<sub>2</sub>") with pinking shears or 3mm scallop shears. Centre each piece of felt on a lining piece and hold in place with a French knot at each upper corner using two strands of **B**, working through all layers (diag 13).

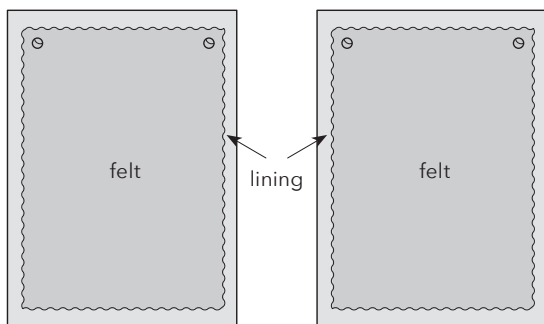

diag 13

With wrong sides together and matching edges, stitch the lining pieces to the linen pieces using joining stitch and the red sewing thread. Place the front and back together so that the edges are aligned and secure with an elastic band down the length (diag 14).

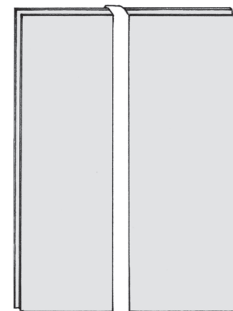

diag 14

Press the length of **G** and thread each end into a tapestry needle. Beginning at the upper edge take one end of the ribbon through the first back stitch on the back cover and the other end through the first back stitch on the front cover (diag 15).

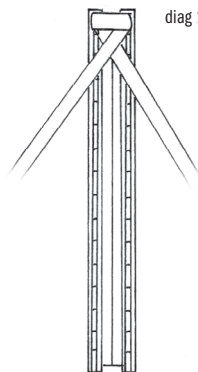

diag 15

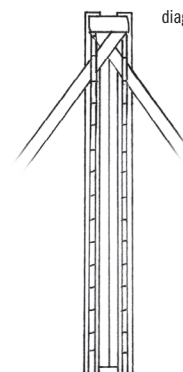

diag 16

Take care to ensure that the ribbon is centred and remains flat. Working in the same manner as lacing up shoes, cross the ribbons and take them through the third back stitches on the opposite sides (diag 16).

Taking care to ensure that the ribbon remains flat, continue working in this manner, taking the ribbons through every second back stitch to the base of the covers. After threading the ribbons through the last back stitch on each side, remove the needles and tie the ribbon tails into a bow. Trim away any excess ribbon.

### 11. Scissor fob

Using the photocopy templates, cut a piece of interlining to fit inside the back stitch border on each piece. Position the interlining, mitre and stitch the corners and fold in the seam allowances on each piece. Lace the edges if desired and press gently. With wrong sides together and matching edges, place the two fob squares together. Using **A**, stitch the pieces together with joining stitch between **A** and **B** (diag 17).

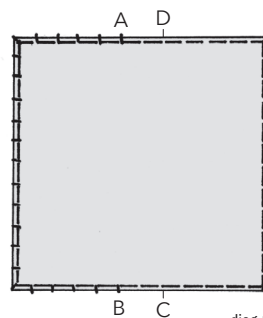

diag 17

Open the panels and insert the cord with the tassel end down. Close the panels and continue stitching from **C** to **D**. Take care not to catch the cord as this will prevent the fob from sliding up and down. Attach the looped end of the cord to a small pair of scissors.

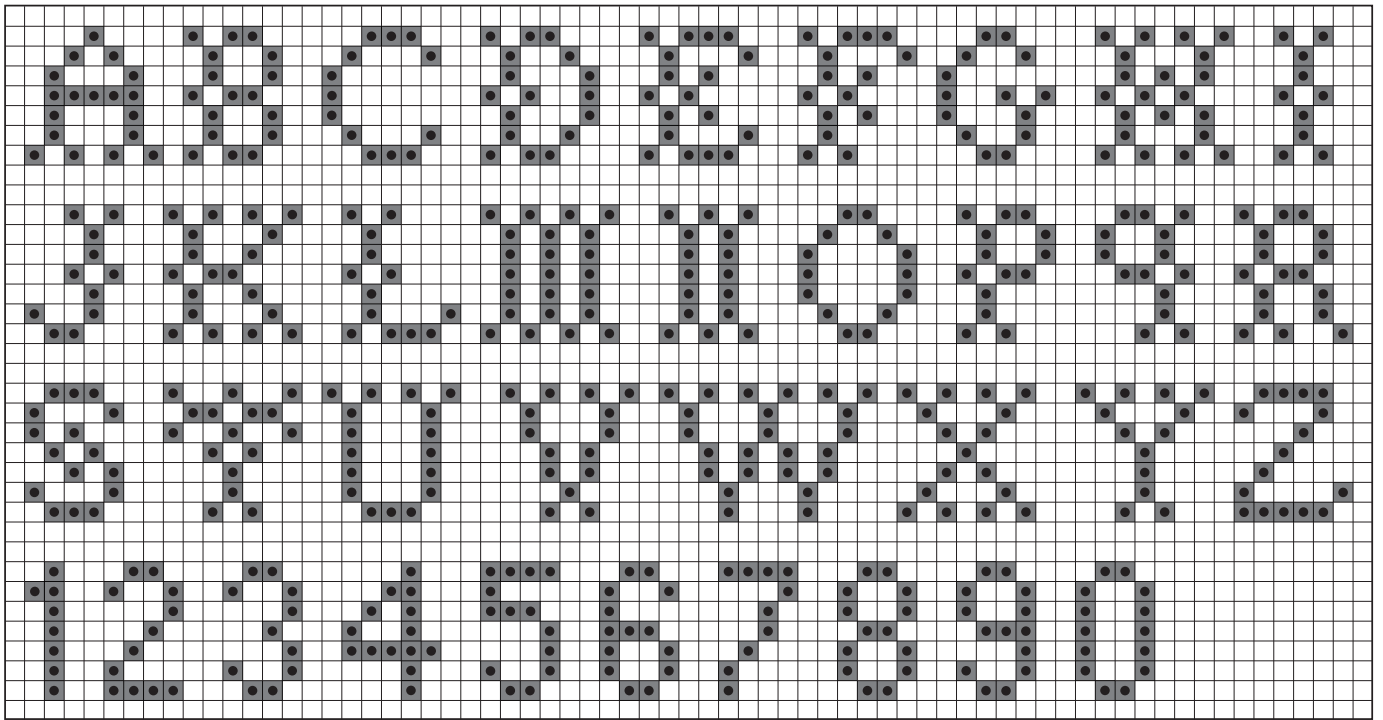

ALPHABET AND NUMBERS CHART

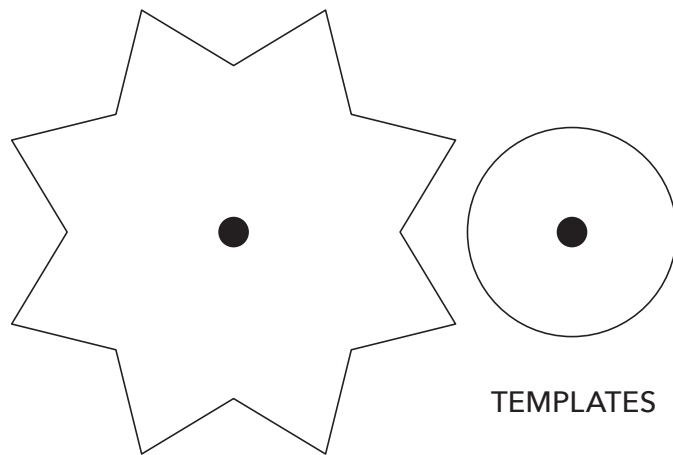

TEMPLATES